



描述

系列防爆型LED防爆灯罩,采用压铸铝材料,具有优良的散热性能,并采用最新LED光源,能效高,体积小,重量轻,使用寿命长,安装方便,适用于各种危险场所,如石油、化工、医药、冶金、船舶、港口、码头、仓库、隧道、矿井、工厂、车间、道路、广场、公园、体育场、学校、医院、酒店、商场、办公室、家庭等。

系列防爆型LED防爆灯罩,采用压铸铝材料,具有优良的散热性能,并采用最新LED光源,能效高,体积小,重量轻,使用寿命长,安装方便,适用于各种危险场所,如石油、化工、医药、冶金、船舶、港口、码头、仓库、隧道、矿井、工厂、车间、道路、广场、公园、体育场、学校、医院、酒店、商场、办公室、家庭等。

系列防爆型LED防爆灯罩,采用压铸铝材料,具有优良的散热性能,并采用最新LED光源,能效高,体积小,重量轻,使用寿命长,安装方便,适用于各种危险场所,如石油、化工、医药、冶金、船舶、港口、码头、仓库、隧道、矿井、工厂、车间、道路、广场、公园、体育场、学校、医院、酒店、商场、办公室、家庭等。

系列防爆型LED防爆灯罩,采用压铸铝材料,具有优良的散热性能,并采用最新LED光源,能效高,体积小,重量轻,使用寿命长,安装方便,适用于各种危险场所,如石油、化工、医药、冶金、船舶、港口、码头、仓库、隧道、矿井、工厂、车间、道路、广场、公园、体育场、学校、医院、酒店、商场、办公室、家庭等。

- 压铸铝外壳
- LED光源
- 压铸铝外壳
- 压铸铝外壳
- 压铸铝外壳
- 压铸铝外壳

1 区和 2 区
21 区和 22 区
Zone 1 and zone 2
Zone 21 and zone 22

Descriptions:

This series of explosion-proof light fittings are made of aluminum alloy with the latest LED light source, which has high efficiency, long life, and low power consumption. It is suitable for various hazardous environments such as oil, chemical, pharmaceutical, metallurgy, ship, port, warehouse, tunnel, mine, factory, workshop, road, square, park, stadium, school, hospital, hotel, shopping mall, office, home, etc. The explosion-proof light fittings are made of aluminum alloy with the latest LED light source, which has high efficiency, long life, and low power consumption. It is suitable for various hazardous environments such as oil, chemical, pharmaceutical, metallurgy, ship, port, warehouse, tunnel, mine, factory, workshop, road, square, park, stadium, school, hospital, hotel, shopping mall, office, home, etc. The explosion-proof light fittings are made of aluminum alloy with the latest LED light source, which has high efficiency, long life, and low power consumption. It is suitable for various hazardous environments such as oil, chemical, pharmaceutical, metallurgy, ship, port, warehouse, tunnel, mine, factory, workshop, road, square, park, stadium, school, hospital, hotel, shopping mall, office, home, etc. The explosion-proof light fittings are made of aluminum alloy with the latest LED light source, which has high efficiency, long life, and low power consumption. It is suitable for various hazardous environments such as oil, chemical, pharmaceutical, metallurgy, ship, port, warehouse, tunnel, mine, factory, workshop, road, square, park, stadium, school, hospital, hotel, shopping mall, office, home, etc.

The explosion-proof light fittings are made of aluminum alloy with the latest LED light source, which has high efficiency, long life, and low power consumption. It is suitable for various hazardous environments such as oil, chemical, pharmaceutical, metallurgy, ship, port, warehouse, tunnel, mine, factory, workshop, road, square, park, stadium, school, hospital, hotel, shopping mall, office, home, etc.

The explosion-proof light fittings are made of aluminum alloy with the latest LED light source, which has high efficiency, long life, and low power consumption. It is suitable for various hazardous environments such as oil, chemical, pharmaceutical, metallurgy, ship, port, warehouse, tunnel, mine, factory, workshop, road, square, park, stadium, school, hospital, hotel, shopping mall, office, home, etc.

- Explosion-proof light fittings
- Explosion-proof light fittings
- Explosion-proof light fittings
- Explosion-proof light fittings
- Explosion-proof light fittings
- Explosion-proof light fittings

● **产品特点 Product characteristics:**



国际认证笼式接线端子，更方便接线
It is easier to be wired by cage type terminal which is certified internationally.



联锁开关确保开盖后自动断电，更安全
It is safer for the interlock switch to be switched off automatically after the light fitting is uncovered.



灯具可按要求配置灯伞
The light fitting can be equipped with the lamp shade as request.



灯具可按要求配置不锈钢网罩
The stainless steel mesh can be equipped as per the request



玻璃罩套件与灯体之间采用套圈挂钩式设计，更方便安装、维护
It is more convenient to be installed and maintained due to the design of ferrule suspension hook type, between the glass cover and the light fitting body.



吸壁式安装，多个位置45°调节
The wall type have many positions with 45° rotation.



吊链式安装 Chain type



吸顶式安装更方便，更安全
The ceiling type is easier and safer to be mounted.

● **多种电缆引入装置 Many kinds of cable glands:**

CZ0226 增安型电缆密封套(填料函)
CZ0226 Increased safety cable glands (stopping boxes)

CZ0223 塑料空塞堵头
CZ0223 Moulded plastic stopping plugs



CZ0220 塑料电缆密封套
CZ0220 Moulded plastic cable glands

CZ0227 金属电缆密封套
CZ0227 Metal cable glands

● **主要数据 Main technical data:**

认证 Certification | 防爆标志 Ex mark | 符合标准 Meet the standard

China (CQST Ex)	Ex de II C T* DIP A2I Ta,T*	GB3836 GB12476
IECEX	Ex de II C T* DIP A2I Ta,T*	IECEx 11.01.01

ATEX 52-2002/2003/2004/2006/2007/2009/2010/2011/2012/2013/2014/2015/2016/2017/2018/2019/2020

防爆标志 Ex de II C T* DIP A2I Ta,T*

防爆标志 Ex de II C T*

防爆标志 Ex de II C T*

防爆标志 Ex de II C T* DIP A2I Ta,T*

防爆标志 Ex de II C T*

防爆标志 Ex de II C T*

防爆标志 Ex de II C T* DIP A2I Ta,T*

防爆标志 Ex de II C T*

防爆标志 Ex de II C T*

防爆标志 Ex de II C T* DIP A2I Ta,T*

防爆标志 Ex de II C T*

防爆标志 Ex de II C T*

防爆标志 Ex de II C T*

防爆标志 Ex de II C T* DIP A2I Ta,T*

防爆标志 Ex de II C T*

防爆标志 Ex de II C T* DIP A2I Ta,T*

防爆标志 Ex de II C T*

防爆标志 Ex de II C T*

● **主要规格 Main specifications:**

1. 防爆标志 Ex de II C T* DIP A2I Ta,T*

2. 防爆标志 Ex de II C T*

3. 防爆标志 Ex de II C T*

4. 防爆标志 Ex de II C T* DIP A2I Ta,T*

5. 防爆标志 Ex de II C T*

6. 防爆标志 Ex de II C T*

7. 防爆标志 Ex de II C T* DIP A2I Ta,T*

8. 防爆标志 Ex de II C T*

9. 防爆标志 Ex de II C T*

10. 防爆标志 Ex de II C T* DIP A2I Ta,T*

11. 防爆标志 Ex de II C T*

12. 防爆标志 Ex de II C T*

13. 防爆标志 Ex de II C T* DIP A2I Ta,T*

14. 防爆标志 Ex de II C T*

15. 防爆标志 Ex de II C T*

16. 防爆标志 Ex de II C T* DIP A2I Ta,T*

17. 防爆标志 Ex de II C T*

18. 防爆标志 Ex de II C T*

19. 防爆标志 Ex de II C T* DIP A2I Ta,T*

20. 防爆标志 Ex de II C T*

21. 防爆标志 Ex de II C T*

22. 防爆标志 Ex de II C T* DIP A2I Ta,T*

23. 防爆标志 Ex de II C T*

24. 防爆标志 Ex de II C T*

25. 防爆标志 Ex de II C T* DIP A2I Ta,T*

26. 防爆标志 Ex de II C T*

27. 防爆标志 Ex de II C T*

28. 防爆标志 Ex de II C T* DIP A2I Ta,T*

29. 防爆标志 Ex de II C T*

30. 防爆标志 Ex de II C T*

31. 防爆标志 Ex de II C T* DIP A2I Ta,T*

32. 防爆标志 Ex de II C T*

33. 防爆标志 Ex de II C T*

34. 防爆标志 Ex de II C T* DIP A2I Ta,T*

35. 防爆标志 Ex de II C T*

36. 防爆标志 Ex de II C T*

37. 防爆标志 Ex de II C T* DIP A2I Ta,T*

38. 防爆标志 Ex de II C T*

39. 防爆标志 Ex de II C T*

40. 防爆标志 Ex de II C T* DIP A2I Ta,T*

41. 防爆标志 Ex de II C T*

42. 防爆标志 Ex de II C T*

43. 防爆标志 Ex de II C T* DIP A2I Ta,T*

44. 防爆标志 Ex de II C T*

45. 防爆标志 Ex de II C T*

46. 防爆标志 Ex de II C T* DIP A2I Ta,T*

47. 防爆标志 Ex de II C T*

48. 防爆标志 Ex de II C T*

49. 防爆标志 Ex de II C T* DIP A2I Ta,T*

50. 防爆标志 Ex de II C T*

CZ0871-2B-010-W204-1-B-

CZ0871-2B-010-W214-1-B-

CZ0871-2B-010-W207-1-B-

CZ0871-2B-010-W217-1-B-

CZ0871-2B-010-W214-1-B-

CZ0871-2B-010-W209-1-B-

CZ0871-2B-010-W205-1-B-

CZ0871-2B-010-W209-1-B-

CZ0871-2B-010-W204-1-B-

CZ0871-2B-010-W214-1-B-

CZ0871-2B-010-W214-1-B-

CZ0871-2B-010-W214-1-B-

CZ0871-2B-010-W204-1-B-

CZ0871-2B-010-W204-1-B-

主要数据 Main technical data:

认证 Certification | 防爆标志 Ex mark | 符合标准 Meet the standard

China (CQST Ex)	Ex de II C T* DIP A21 Ta,T*	GB3836 GB12476
IECEX	Ex de II C T* Gb Ex tb III C T195°C/T130°C/T95°C/T80°C Db	IEC60079
ATEX	⊕ II 2 GD Ex de II C T* Gb Ex tb III C T195°C/T130°C/T95°C/T80°C Db	EN60079

适用范围: 用于 1 区和 2 区 用于 21 区和 22 区

防护等级: IP66

 额定电压: 220V AC 50Hz
 220V AC, 230V AC, 240V AC 50Hz, 60Hz

 使用环境温度: -20°C to +40°C/+55°C
 -40°C to +40°C/+55°C

 接线端子: L1, N 笼式端子 2-2.5mm², PE 端子 2 × 10mm²

 电缆入口: 塑制 1 × M25 × 1.5, 电缆外径: Φ8-17mm
 塑制 1 × M25 × 1.5 空塞堵头

Intended use: Can be used in zone 1 and zone 2

Can be used in zone 21 and zone 22

Degree of protection: IP66

 Rated voltage: 220V AC 50Hz
 220V AC, 230V AC, 240V AC 50Hz, 60Hz

 Ambient temperature: -20°C to +40°C/+55°C
 -40°C to +40°C/+55°C

 Terminal: L1, N Cage type terminal 2-2.5mm², PE terminal: 2 × 10mm²

Cable entry: Moulded plastic 1 × M25 × 1.5,

Outside diameter: Φ8-17mm

Moulded plastic 1 × M25 × 1.5 stopping plug

订购规格 Order specifications:

图样 Illustration	光源代号 Light source code	灯座代号 Lampholder code	功率 Power	温度组别 T* Temperature class*		重量 Weight	订购号 Order No.
				Ta ≤ 40°C	Ta ≤ 55°C		
 CZ0872	电磁感应节能灯-QL Electromagnetic induction energy-saving lamp-QL		135W	T5	T4	12.8kg	CZ0872/2B-QL135W57-□-B+□
			165W	T5	T4	13kg	CZ0872/2B-QL165W57-□-B+□
	白炽灯-B Incandescent lamp-B	E40	500W	T4	/	11.9kg	CZ0872/2B-B500W25-□-B+□
	自镇流汞灯-Z Self-ballasted mercury vapor lamp-Z	E40	500W	T3	/	12kg	CZ0872/2B-Z500W25-□-B+□
	金属卤化物灯-J Metal halide lamp-J	E40	250W	T5	T4	15.8kg	CZ0872/2B-J250W25-□-B+□
			400W	T4	/	16kg	CZ0872/2B-J400W25-□-B+□
	高压钠灯-N High pressure sodium vapor lamp-N	E40	150W	T4	T4	17.2kg	CZ0872/2B-N150W25-□-B+□
			250W	T5	T4	18kg	CZ0872/2B-N250W25-□-B+□
			400W	T4	/	20kg	CZ0872/2B-N400W25-□-B+□

额定电压 Rated voltage ←

 2 — 220V AC 5 — 220V ~ 240V AC
 3 — 230V AC 6 — 230V/240V AC
 4 — 240V AC

额定频率 Rated frequency ←

 5 — 50Hz
 6 — 60Hz
 7 — 50/60Hz

使用环境温度 Ambient temperature ←

 2 — -20°C to +40°C/+55°C
 4 — -40°C to +40°C/+55°C

电缆引入装置编码详见第05页 Code of cable gland see page 05 ←

安装附件订购号 (不配不注) 附件见 09-10 页 ←

Order No. of mounting accessories (No matching not noted), see page 09-10

● 电缆引入编码 Code of cable gland:

编码 Code	规格 Specification	电缆直径 Cable diameter
B	塑制 1 个 M25 × 1.5 电缆密封套, 塑制 1 个 M25 × 1.5 空塞堵头 One moulded plastic M25 × 1.5 cable gland, one moulded plastic M25 × 1.5 stopping plug	Φ8-17mm
C	铜制 1 个 CZ0221/M25 × 1.5 金属电缆密封套, 塑制 1 个 M25 × 1.5 空塞堵头 One brass CZ0221/M25 × 1.5 metal cable gland, one moulded plastic M25 × 1.5 stopping plug	Φ8-17mm
D	塑制 2 个 M25 × 1.5 电缆密封套 Two moulded plastic M25 × 1.5 cable glands	Φ8-17mm
E	铜制 2 个 CZ0221/M25 × 1.5 金属电缆密封套 Two brass CZ0221/M25 × 1.5 metal cable glands	Φ8-17mm
F	铜制 1 个 CZ0227/M25 × 1.5-G ^{3/4} 增安型金属电缆密封套, 塑制 1 个 M25 × 1.5 空塞堵头 One brass CZ0227/M25 × 1.5-G ^{3/4} increased safety metal cable gland, one moulded plastic M25 × 1.5 stopping plug	Φ11-15mm
G	铜制 2 个 CZ0227/M25 × 1.5-G ^{3/4} 增安型金属电缆密封套 Two brass CZ0227/M25 × 1.5-G ^{3/4} increased safety metal cable glands	Φ11-15mm
H	铜制 1 个 CZ0226/M25 × 1.5-(G02) 增安型金属电缆密封套(填料函), 塑制 1 个 M25 × 1.5 空塞堵头 One brass CZ0226/M25 × 1.5-(G02) increased safety metal cable gland (stopping boxes), one moulded plastic M25 × 1.5 stopping plug	Φ11.5-16mm
I	铜制 2 个 CZ0226/M25 × 1.5-(G02) 增安型金属电缆密封套(填料函) Two brass CZ0226/M25 × 1.5-(G02) increased safety metal cable glands (stopping boxes)	Φ11.5-16mm

☆注: 表示该灯具不能实现带联锁开关。Note: This light fitting can not be fitted with interlock switch.

● 配光曲线 Luminous intensity distribution curve:

光强单位 luminous intensity unit : cd/klm

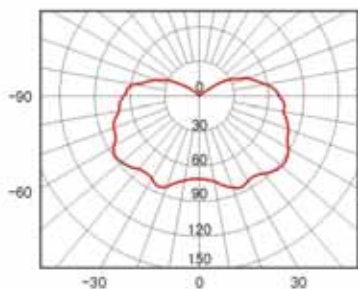

CZ0871-JN45W 节能灯
Energy-saving lamp

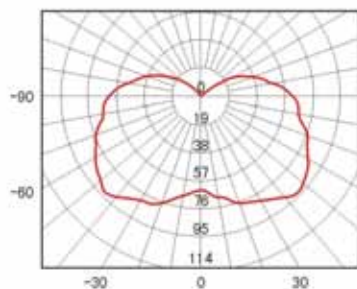

CZ0871-JN65W 节能灯
Energy-saving lamp

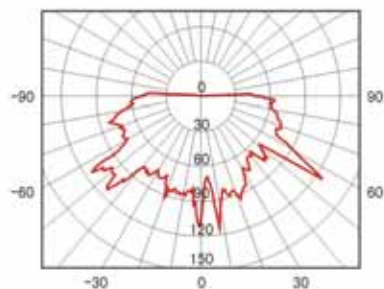

CZ0871-B200W 白炽灯
Incandescent lamp

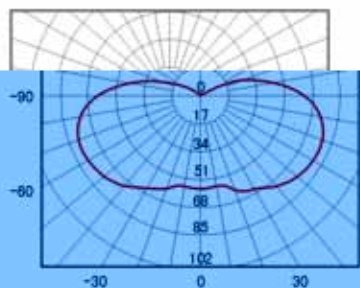

CZ0871-QL50W 电磁感应节能灯
Electromagnetic induction energy-saving lamp

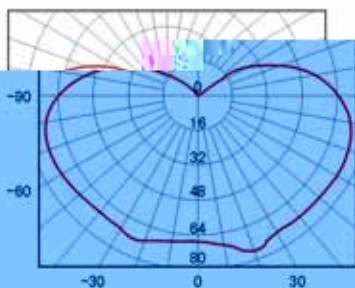

CZ0871-QL85W 电磁感应节能灯
Electromagnetic induction energy-saving lamp

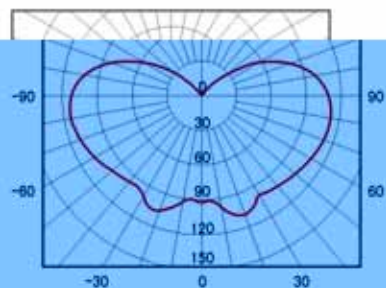

CZ0872-QL135W 电磁感应节能灯
Electromagnetic induction energy-saving lamp

• 配光曲线 Luminous intensity distribution curve:

光强单位 luminous intensity unit : cd/klm

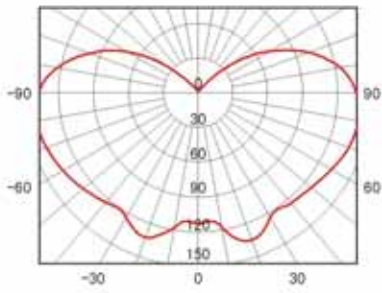

CZ0872-QL165W 电灯

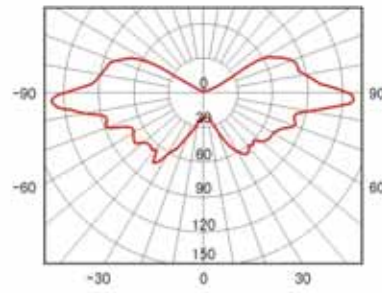

CZ0871-QL165W 电灯

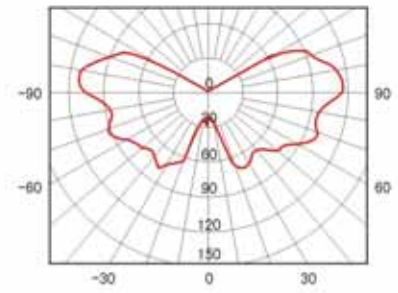

CZ0872-QL165W 电灯





描述

防爆应急灯外壳由铝合金压铸成型，表面喷涂纯环氧树脂粉末，抗腐蚀性能好。透明罩采用硼硅酸盐钢化玻璃，外露紧固件采用不锈钢材料，玻璃罩套件与灯体之间采用套圈挂钩设计。防爆灯的接线盒侧面进线，适用于橡胶套和铠装电缆布线，内部接线端子选用菲尼克斯国际认证笼式端子，便于接线。防爆灯具内部独特的隔热设计与外部高密度的散热片相结合散热效果更佳。能满足石化、化学和海上工业照明的相关要求。

防爆应急灯内装有镇流器、逆变器、锂电池、金属卤化物灯泡和隔离开关。本灯具具有自动断电功能，在更换灯泡时，打开玻璃罩套件，灯具自动切断前级电源、灯泡电源和电池放电电源，确保安全。

防爆应急灯在正常使用时自动充电，事故断电或停电时自动点亮灯泡。

防爆应急灯的安装形式分为吸顶式、吸壁式、吊链式。

- 防爆最高等级IIC级
- 防护等级高达IP66
- 四项专利技术
- 安装维护方便

Descriptions:

The enclosures of multi-source explosion-proof emergency light fittings are die-cast manufactured of aluminum alloy, with the surfaces sprayed epoxy resin powder, therefore they have good anti-corrosion performance. The transparent shield is made by the toughened glass of borosilicate, the exposed fasteners are the stainless steel, between the suites of toughen glass and the light fitting body are used femule suspension hook design. Explosion-proof light fitting's terminal box side entry, is suitable for rubber-coated and the armored cable wiring, the Phoenix internationally certified cage type terminals are selected as internal terminals, which are convenient for the wiring. The unique heat insulation design united with the exterior high density's radiator in the explosion-proof light fitting to cause the radiation effect will be better. It can satisfy the related requirements in petrochemical, chemical and marine industries.

The explosion-proof emergency light fittings contain ballasts, inverters, lithium batteries, metal halide lamps and isolation switches. With the function of automatic power off for the light fittings, the former power supply, the power supply of the bulb and discharging power will be cut off while opening the suites of the toughen glass cover during replacing of the battery, which ensures the safety.

The light fitting can be automatically recharged while normal working, so that the lamp tube will turn on when the power loses of fails because of the accident.

The mounting ways of the explosion-proof platform light fitting are fence type and platform flange type.

- The highest class of flameproof is up to IIC.
- The degree of protection is up to IP66.
- The four patented technologies were obtained.
- It is convenient to be mounted and maintained.

- 配光曲线 Luminous intensity distribution curve:
光强单位 luminous intensity unit: cd/klm

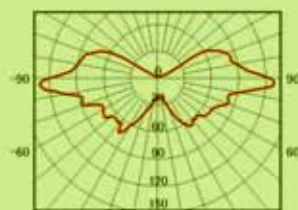

CZ0871-J50W YJ

1 区和 2 区
21 区和 22 区

Zone 1 and zone 2
Zone 21 and zone 22

- 应急灯具安装线路图
Mounting circuit diagram for emergency light fittings:

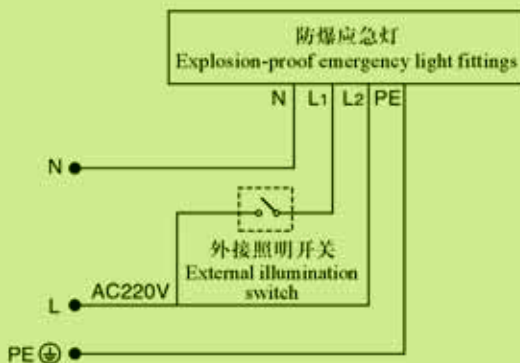

● 主要数据 Main technical data:

认证 Certifications: CE, RoHS, Ex, UL, FCC, CCC, AT, PSE, ENEC, GOST, VDE, IEC, EMC, LVD, Low Voltage Directive, Energy Star, Energy Efficient, Energy Star, Energy Efficient, Energy Star, Energy Efficient

● CZ0871 YJ Explosion-proof emergency light

Model: CZ0871 YJ
Material: Aluminium alloy, PC
Power: 15W
Voltage: 220-240VAC/120-130VAC
Frequency: 50/60Hz
Life span: 100,000 hours
IP Rating: IP65



● CZ0871 YJ Explosion-proof emergency light









Model: CZ0871 YJ
Material: Aluminium alloy, PC
Power: 15W
Voltage: 220-240VAC/120-130VAC
Frequency: 50/60Hz
Life span: 100,000 hours
IP Rating: IP65



● 安装附件、备件 Mounting accessories, spare parts:

图 样 Illustration	描 述 Descriptions	单 位 Unit	订 购 号 Order No.
安装支架 Mounting bracket 	用于 CZ0871 灯具, 材料为优质钢表面喷塑处理 Used for CZ0871 light fittings, the material is high quality steel with sprayed plastic surface	套 Set	D8701/1
	用于 CZ0872 灯具, 材料为优质钢表面喷塑处理 Used for CZ0872 light fittings, the material is high quality steel with sprayed plastic surface	套 Set	D8701/2
吊式安装支架 Mounting bracket of pendant type 	用于 CZ0871 灯具, 材料为优质钢表面喷塑处理 Used for CZ0871 light fittings, the material is high quality steel with sprayed plastic surface	套 Set	D8702/1
	用于 CZ0872 灯具, 材料为优质钢表面喷塑处理 Used for CZ0872 light fittings, the material is high quality steel with sprayed plastic surface	套 Set	D8702/2
吊链式附件 Chain type accessories 	M8 吊环螺钉安装, 材料为优质钢表面镀锌处理 For M8 lifting eye bolt, the material is high quality steel with galvanization on surface	套 Set	D623
G3/4" 直管 G3/4" Straight pipe 	用于灯具吊杆式 For pendant type light fittings	套 Set	D732
护栏式灯杆 Lamp pole of fence type 	用于 CZ0871、CZ0872, 材质为优质镀锌钢, 表面喷塑 Used for CZ0871, CZ0872, material is high quality galvanized steel, with the surface sprayed plastic.	套 Set	D8705
法兰式灯杆 Lamp pole of flange type 	用于 CZ0871、CZ0872, 材质为优质镀锌钢, 表面喷塑 Used for CZ0871, CZ0872, material is high quality galvanized steel, with the surface sprayed plastic.	套 Set	D8706
单臂马路灯杆 Lamp pole of single arm street light 	用于 CZ0871、CZ0872, 材质为优质镀锌钢, 表面喷塑 Used for CZ0871, CZ0872, material is high quality galvanized steel, with the surface sprayed plastic.	套 Set	D8707
双臂马路灯杆 Lamp pole of double arms street light 	用于 CZ0871、CZ0872, 材质为优质镀锌钢, 表面喷塑 Used for CZ0871, CZ0872, material is high quality galvanized steel, with the surface sprayed plastic.	套 Set	D8708
软管 Flexible conduit 	用于灯杆与灯具的连接 Used for connecting the lamp poles and the light fittings	套 Set	D8720
玻璃罩套件 Parts of toughen glass cover 	用于 CZ0871 灯具, 带不锈钢套环 Used for CZ0871 light fittings, with stainless steel ringer	套 Set	D8703/1
	用于 CZ0872 灯具, 带不锈钢套环 Used for CZ0872 light fittings, with stainless steel ringer	套 Set	D8703/2
网罩 Mesh 	用于 CZ0871 灯具, 材质为不锈钢 Used for CZ0871 light fittings, the material is stainless steel	套 Set	D8704/1
	用于 CZ0872 灯具, 材质为不锈钢 Used for CZ0872 light fittings, the material is stainless steel	套 Set	D8704/2
灯伞 lamp shade 	用于 CZ0871 灯具 Used for CZ0871 light fittings	只 Piece	D8724/1
	用于 CZ0872 灯具 Used for CZ0872 light fittings	只 Piece	D8724/2
陶瓷灯座 Ceramics lampholder 	规格 Specification: E27	只 Piece	K547H
	规格 Specification: E40	只 Piece	K548

● 光源备件 Spare parts of light source:

图样 Illustration	功率 Power	灯座 Lampholder	光通量 Luminous flux	单位 Unit	订购号 Order No.
欧司朗品牌节能灯泡(螺旋型) "OSRAM" energy-saving lamp bulb (Helix type) 	45W	E27	2850lm	只Piece	OSRAM/45W
	65W	E27	4000lm	只Piece	OSRAM/65W
自镇流汞灯-Z Self-ballasted mercury vapor lamp blub-Z 	125W	E27	1650lm	只Piece	HWL/125W
	160W	E27	3100lm	只Piece	HWL/160W
	250W	E40	5600lm	只Piece	HWL/250W
	500W	E40	14000lm	只Piece	HWL/500W
白炽灯-B Incandescent lamp blub-B 	200W	E27	2920lm	只Piece	PZ/200W
	300W	E40	4160lm	只Piece	PZ/300W
	500W	E40	8300lm	只Piece	PZ/500W
电磁感应节能灯泡体 Electromagnetic induction energy-saving lamp bulb 	50W	电磁感应 节能灯泡体 Electromagnetic induction energy-saving lamp bulb	2800lm	只Piece	WJ50T
	85W		5600lm	只Piece	WJ85P
	135W		8800lm	只Piece	WJ135PA
	165W		10000lm	只Piece	WJ165PA
高频发生器 High frequency generator 	50W	高频发生器 High frequency generator	/	只Piece	HFG-50AC
	85W		/	只Piece	HFG-85AC
	135W		/	只Piece	HFG-135AC
	165W		/	只Piece	HFG-165AC
金属卤化物灯泡-J Metal halide lamp bulb-J 	50W	E27	3400lm	只Piece	JL Z50KN
	70W	E27	5000lm	只Piece	HQI - E 70/N
	100W	E27	8700lm	只Piece	HQI - E 100/N
	150W	E27	12500lm	只Piece	HQI - E 150/N
	250W	E40	20500lm	只Piece	HQI - T 250/D
	400W	E40	32000lm	只Piece	HQI - BT 400/D
高压钠灯灯泡-N High pressure sodium vapor lamp bulb-N 	70W	E27	5900lm	只Piece	NAV - T 70
	100W	E27	10000lm	只Piece	NAV - T 100SUPER
	150W	E40	14500lm	只Piece	NAV - T 150
	250W	E40	27000lm	只Piece	NAV - T 250
	400W	E40	48000lm	只Piece	NAV - T 400
高压汞灯灯泡-G High pressure mercury vapor lamp bulb-G 	125W	E27	6300lm	只Piece	HQL - 125

• 外形及安装尺寸 Outline and installation dimensions:

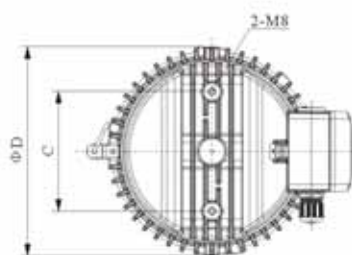
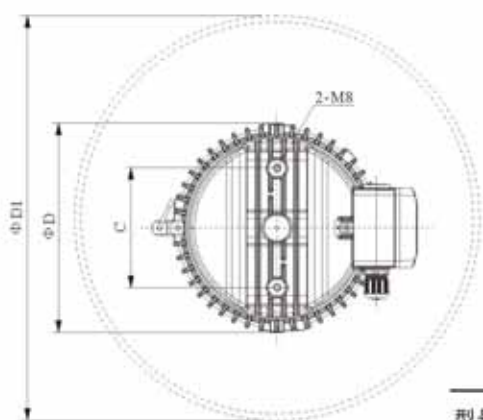
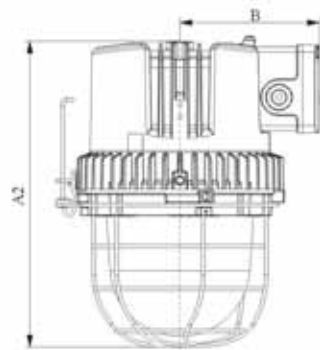
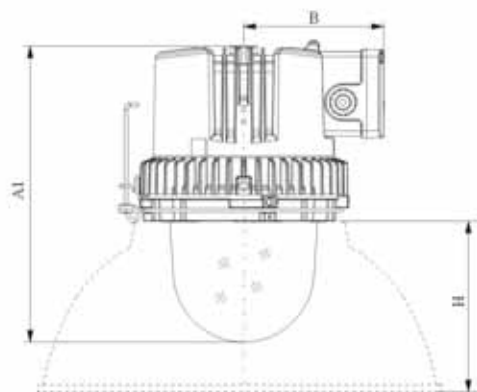

型号 Type	A1	A2	A3	A4	B	C	ΦD	ΦD ₁	E	F	G	H
CZ0871	350	360	410	500	165	140	245	475	220	245	140	200
CZ0872	500	510	560	660	190	160	300	685	268	280	160	260

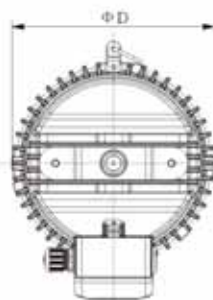
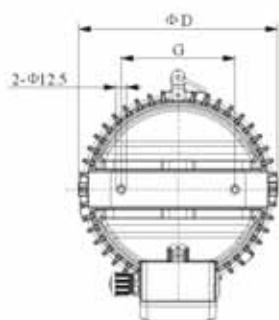
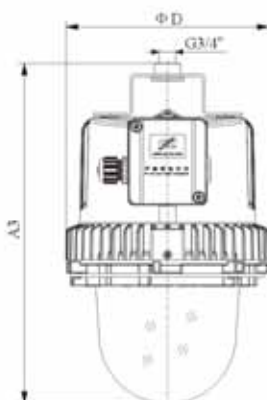
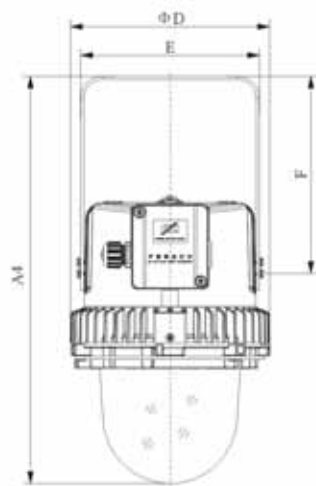

• 外形及安装尺寸 Outline and installation dimensions:

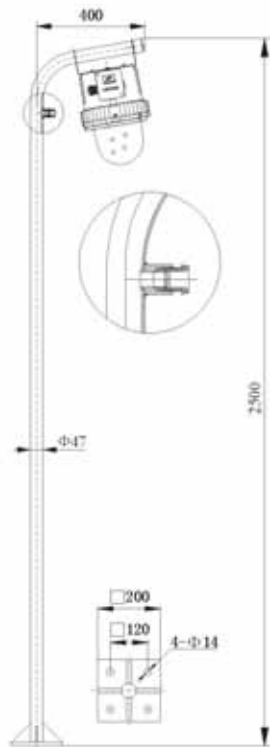

法兰式安装
Flange type

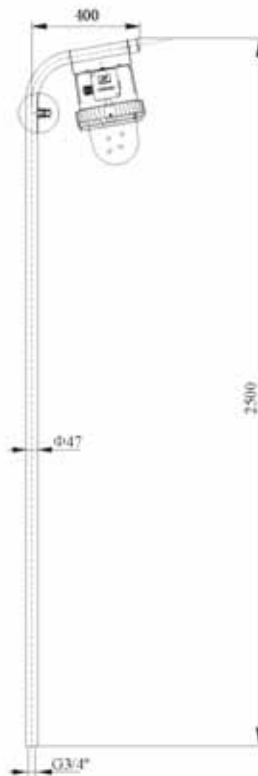

护栏式安装
Fence type



单臂马路灯杆
Lamp pole of single arm street light



双臂马路灯杆
Lamp pole of double arms street light

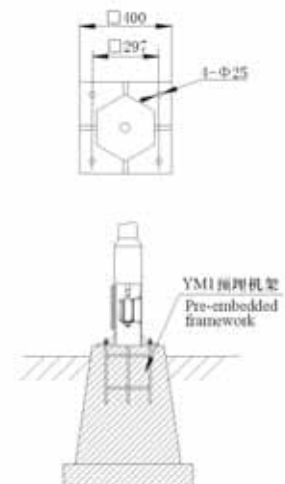

路灯混凝土基础示意图
Street light concrete base diagram